

Does emotional exhaustion influence turnover intention among early-career employees? A moderated-mediation study on Malaysian SMEs

Tajneen Affnaan Saleh, Abdullah Sarwar, Nasreen Khan, Mosab I. Tabash & Mohammad Imtiaz Hossain

To cite this article: Tajneen Affnaan Saleh, Abdullah Sarwar, Nasreen Khan, Mosab I. Tabash & Mohammad Imtiaz Hossain (2023) Does emotional exhaustion influence turnover intention among early-career employees? A moderated-mediation study on Malaysian SMEs, Cogent Business & Management, 10:3, 2242158, DOI: [10.1080/23311975.2023.2242158](https://doi.org/10.1080/23311975.2023.2242158)

To link to this article: <https://doi.org/10.1080/23311975.2023.2242158>



© 2023 The Author(s). Published by Informa UK Limited, trading as Taylor & Francis Group.



Published online: 03 Sep 2023.



Submit your article to this journal [↗](#)



Article views: 620



View related articles [↗](#)



View Crossmark data [↗](#)



Received: 25 March 2023
Accepted: 25 July 2023

*Corresponding author: Abdullah Sarwar, Faculty of Management, Malaysia Multimedia University, Cyberjaya 63100, Malaysia
E-mail: abdullah.sarwar@mmu.edu.my

*Mosab I. Tabash, College of Business, Al Ain University, Al Ain, United Arab Emirates
E-mail: mosab.tabash@aau.ac.ae

Reviewing editor:
Virginia Barba-Sánchez, Universidad de Castilla-La Mancha - Campus de Albacete, Spain

Additional information is available at the end of the article

MANAGEMENT | RESEARCH ARTICLE

Does emotional exhaustion influence turnover intention among early-career employees? A moderated-mediation study on Malaysian SMEs

Tajneen Affnaan Saleh¹, Abdullah Sarwar^{1*}, Nasreen Khan¹, Mosab I. Tabash^{2*} and Mohammad Imtiaz Hossain¹

Abstract: The aim of the present study was to investigate the relationship between early-career employees' emotional exhaustion and turnover intention in the information technology sector. Given the scarce empirical evidence on how turnover intention and emotional exhaustion can be reduced among early-career employees, ethical leadership was investigated as a mediator in this relationship based on the Social Exchange Theory (SET). Furthermore, using the Conservation of Resource Theory (COR), this study sought to understand the moderating role of a specific organizational ethical climate (i.e. self-interest climate) in the relationships among emotional exhaustion, ethical leadership, and turnover intention. Data was collected using convenience sampling from 243 early-career employees working in small and medium enterprises in the information technology sector. The results of structural equation modeling (SEM) indicated that early-career employees' emotional exhaustion significantly increases their turnover intention. This effect was found to be mediated by low ethical leadership and moderated by the self-interest ethical climate. However, the findings did not support the moderating effect of the self-interest ethical climate on the relationship between ethical leadership and employees' turnover intention. This study contributes to the existing knowledge on COR and SET by incorporating the antecedents of turnover intention, which have a significant impact on employees' decision-making regarding withdrawal. Additionally, the study addresses the underexplored topic of specific ethical climates and their effects on employees. By examining how a key antecedent of turnover intention operates within an organizational self-interest ethical climate, this paper advances our understanding of this complex phenomenon. A discussion of the study's limitations and suggestions for future research conclude the paper.

Subjects: Human Resource Management; Organizational Studies;

Keywords: emotional exhaustion; ethical leadership; self-interest ethical climate; turnover intention; moderated mediation

1. Introduction

Employee turnover poses a significant challenge for organizations that heavily rely on their workforce and strive to strengthen employee-organization attachment quality. Turnover refers to the situation in which an employee voluntarily leaves the organization after expressing a prior intention to withdraw (Skelton et al., 2019). This phenomenon has been a major problem for many years as it leads to the loss of specialized human capital and incurs costs associated with hiring and training replacement staff (Babalola et al., 2016; Hancock et al., 2013). Recent evidence from Sija (2021) has shown a significant increase in the workforce turnover rate, reaching 27.9% in 2019. Research indicates that employees go through an evaluation process before ultimately deciding to quit (Hancock et al., 2013), while a previous study highlighted that approximately 25% of turnover intention actually results in turnover (Sausa-Poza & Sousa-Poza, 2007). Therefore, this study aimed to address the limited understanding of how to mitigate turnover intention among early-career employees in small and medium enterprises (SMEs) in the information technology sector.

The early-career stage is a critical period during which individuals become acclimated to the organization and gain acceptance within the business (Lee et al., 2017). Early-career employees, typically between 18 and 35 years old, are highly valuable for organizations in terms of maintaining their strength and ensuring sustainable development. Zaharee et al. (2018) found that these employees prioritize work-life balance, technology, and making significant contributions to their organizations. Consequently, organizations are keen on retaining early-career employees due to their positive attitudes and potential contributions. However, previous research on turnover intention among early-career employees has predominantly focused on the experiences of new graduates in their first year of employment, with limited attention given to subsequent years of their early-career development (Cosgrave et al., 2018). This is a concerning gap in the literature, as Queiri et al. (2015) found that early-career employees in Asia have shorter employment durations, averaging 18 months compared to previous generations who stayed an average of up to four years. Notably, Black (2010) observed that early-career employees require significant effort to establish a strong relationship with their organization and typically demonstrate less commitment. Therefore, there is a need to examine early-career employees' turnover intention beyond just their initial career experiences.

Moreover, it is crucial to study early-career employees in SMEs, as these organizations play a vital role in economic development and employment growth (Memon et al., 2016), thereby significantly impacting global economies (De Sousa Jabbour et al., 2020). According to data from The World Bank (2020), SMEs account for over 90% of global businesses and have made significant contributions to job creation and inclusive economic development. Pinkovetskaia et al. (2020) also suggested that the development of SMEs has a substantial impact on business relationships. In Malaysia, SMEs play a crucial role in economic growth, making up 98.5% of business establishments and contributing 38.9% to the Gross Domestic Product (GDP) in 2019 (SME Corp, 2019). Recognizing this, the Malaysian government has implemented various programs to enhance the sustainable performance of SMEs (Musa & Chinniah, 2016). However, one major challenge faced by SMEs is their high turnover rate, which leads to labor shortages and increased costs associated with recruitment, staffing, and training (Wen et al., 2020). Furthermore, it has been reported that approximately 61% of the global workforce is engaged in informal and temporary employment, with only 39% employed on a permanent basis (ILO, 2020).

Griffeth et al. (2000) emphasized that the work environment, specifically working conditions, can significantly influence employees' turnover intention by causing emotional exhaustion. In Malaysia, the working population has experienced excessive fatigue, with 58% reporting its impact at least once every three months (Khalil, 2022). This pressing issue necessitates a thorough analysis of the underlying causes to avoid employee dissatisfaction, which may result in decreased job satisfaction and ultimately lead to turnover. Consequently, organizations must closely monitor the occurrence of emotional exhaustion among employees to gain a comprehensive understanding of their changing attitudes and behaviors.

This study makes significant theoretical contributions to the literature on early-career employees' emotional exhaustion and turnover intention in three main aspects. First, it clarifies whether early-career employees' emotional exhaustion is a significant predictor of turnover intention. Previous research has indicated that employees engaged in demanding jobs that require long hours and routine tasks may experience emotional exhaustion (S. H. Chan et al., 2015; Suifan et al., 2020). These employees often face excessive role stress in their work environment, which can push them to consider alternative options and develop withdrawal intentions.

Despite the negative impact of emotional exhaustion on turnover behavior, understanding potential approaches to mitigate the negative consequences associated with turnover intention remains an underexplored area of research. Therefore, the second contribution of this study is its examination of the influence of ethical leadership on early-career employees. Ethical leadership has been found to predict positive outcomes, including employees' job satisfaction, commitment, and willingness to report problems (Bedi et al., 2016; Brown et al., 2005). As such, when guided by an ethical leader, employees may be less likely to waste valuable resources (such as time, energy, and social relationships) and deal with potential workplace risks (such as office politics) (Plantiveau et al., 2018; Riisla et al., 2021). However, limited attention has been given to the relationship between employees' emotional exhaustion amid the presence of an ethical leader. Therefore, guided by the Social Exchange Theory (SET) (Blau, 1964), this research addresses this gap and extends Dust et al. (2018) study by examining how ethical leadership links employees' emotional exhaustion to their behavioral intention to leave the organization.

Third, the study addresses the growing concerns of researchers and practitioners worldwide about corporations' involvement in corruption and immoral behavior, such as in the cases of Enron, National Irish Bank, and Volkswagen (Babalola et al., 2019; Palanski et al., 2021). Previous studies have identified ethical climate as a stressor associated with negative work outcomes, including increased emotional exhaustion and turnover intention (Saleh, Mehmood, et al., 2022; Saleh, Sarwar, et al., 2022). Dealing with a demanding work climate has been linked to emotional exhaustion among employees, as suggested by Maslach and Leiter (2018). Despite the significance of employees' perceptions of the ethical climate, however, limited knowledge exists regarding how the self-interest ethical climate influences early-career employees' responses in SMEs. Consequently, building on the Conservation of Resources (COR) theory, this study examined the moderating influence of the self-interest ethical climate on the relationship between emotional exhaustion and turnover intention, which has been overlooked in previous research.

To make the aforementioned contributions to the literature, this study aimed to answer the following research questions in the context of Malaysian tech SMEs: (i) Is there a relationship between early-career employees' emotional exhaustion and their turnover intention? (ii) Is this relationship mediated by ethical leadership? and (iii) Does the self-interest ethical climate moderate the effects of emotional exhaustion and ethical leadership on turnover intention? By combining these concepts into one comprehensive framework, this study endeavors to address the challenges of reducing turnover intention as well as mitigating the potential negative effects of the self-interest ethical climate among early-career employees in SMEs. This study also offers a better understanding of early-career employees' decision to align themselves with an organization or not, as it draws on the suggestion made by Barattucci et al. (2021) concerning the influence of ethical leadership at the individual level and the self-interest climate as an often overlooked boundary condition (Paterson & Huang, 2018). Moreover, the research delves into ethical leadership as a mechanism that can effectively reduce employee turnover intention, which is a topic that remains unexplored. Thus, this investigation is not only interesting but also highly relevant, as it identifies potential solutions to reduce turnover intention among early-career employees facing significant emotional exhaustion.

2. Literature review

2.1. Employees' emotional exhaustion

Burnout, a psychological condition resulting from prolonged exposure to work-related pressures, reflects an individual's response to specific work conditions (Costa & Moss, 2018; Leiter & Maslach, 2009). It occurs when the organizational climate indirectly impacts employees' health through associated workplace risks or demands (Loh et al., 2019). For instance, a recent systematic literature review by Allam et al. (2022) revealed that burnout is prevalent among female primary teachers due to poor working conditions and a lack of organizational support. This study narrowed its focus to emotional exhaustion, one of three characteristics of work-related burnout (Maslach et al., 2001). Emotional exhaustion refers to the depletion of emotional resources, leading to a loss of energy and leaving individuals without enough resources to fulfill their job requirements (Gupta & Srivastava, 2020). It serves as a primary indicator of burnout and an antecedent to other burnout-related behavioral and emotional concerns (Maslach and Leiter, 2017). Experiencing emotional exhaustion in the workplace is inevitable; it affects individuals across all levels of the organization, from front-line employees to upper management. Xu et al. (2018) observed that emotional exhaustion often occurs during workplace interpersonal encounters when emotional demands surpass coping capacity. Additionally, certain organizational and demographic characteristics may influence emotional exhaustion, as men tend to restrain emotions more than women and may feel less emotionally exhausted (Gross & John, 2003; Purvanova & Muros, 2010).

Research has found that employees who frequently confront challenging organizational situations alone and lack interaction with coworkers or managers are more likely to experience high levels of emotional exhaustion (Plantiveau et al., 2018). As a result, they may develop prolonged stress responses to persistent workplace pressures, which could be linked to cognitive decline among early-career employees (Giorgi et al., 2020). Similarly, Teoh and Kee found that emotional exhaustion is positively linked to obstacles in personal development, as excessive demands can become stressors when individuals fail to properly recover. Consequently, these employees may seek alternative ways to cope and recover from their feelings of exhaustion. Another recent study suggests that job demands are more strongly associated with emotional exhaustion, while job resources are more related to personal accomplishment (Guan & Jepsen, 2020).

Applying the COR theory (Hobfoll, 1988), this study explored the motivational and performance implications of emotional exhaustion. According to COR, employees try to conserve their remaining resources to manage stress and prevent future strain (Halbesleben et al., 2009). In stressful employment settings, valued resources may become depleted, leading to emotional exhaustion (Ain et al., 2022; Reb et al., 2017). Therefore, this study explored the motivational drive among early-career employees to sustain their emotional well-being, as these young employees tend to positively correlate emotional exhaustion with their turnover intention.

2.2. Turnover intention

Organizational success relies on sustainability, encompassing economic, environmental, and social components (Ullah et al., 2021). In this regard, employee turnover has been a persistent and challenging issue affecting organizations' success for decades. According to research by Tarallo (2018) in the U.S., employers spent an average turnover cost of \$600 billion in 2018, with projected annual costs rising to \$680 billion by 2020. As a precursor of turnover, turnover intention refers to the willingness of employees to voluntarily leave their organization (Tett & Meyer, 1993). It arises when there is a conflict between employees' motivation and the firm's working conditions (Cohen et al., 2016). Self-reported turnover intention is often preferable from a practical standpoint compared to researchers' direct observation of actual turnover (Kang et al., 2021).

Since replacing experienced employees takes time and effort (Chiat & Panatik, 2019), numerous studies have been conducted to better understand turnover intention, with the goal of addressing employee retention and enhancing organizational effectiveness (Benevene et al., 2018; Hom et al.,

2012; Reina et al., 2018). According to Demirtas and Akdogan (2019), most scholars have attempted to identify the reasons behind turnover, including external factors (e.g., job availability and unemployment levels), organizational factors (e.g., leadership style, work environment, and reward system), and individual factors (e.g., job dissatisfaction and performance of others). Previous research has also highlighted that turnover intention is exacerbated by management failures attributed to poor leadership (Paterson & Huang, 2018). Additionally, Ponomariov et al. (2020) found that young male employees with short tenures at work are more likely to express turnover intention and consider leaving their workplace.

In Malaysia, employee turnover concerns have been emphasized since the early 1990s, with a growing demand for human resources under challenging working conditions (Keni et al., 2013). However, most of the empirical research on employee turnover has been conducted in non-Asian contexts, particularly in the United States and Canada (Haines et al., 2010; Rondeau and Wagar, 2016). In comparison, there are few empirical studies on the work-related challenges experienced by employees working in SMEs in Malaysia. In light of the significant cost of staff turnover and the persisting struggle to attract and retain high-quality employees, organizations must address the roles of emotional exhaustion (DeConinck, 2014) and ethical climate (S. H. J. Chan & James, 2020) as key factors of turnover to ensure workforce stability. Based on this premise, this study adopted a human resource development approach to reduce turnover intention among early-career employees in the SME sector.

2.3. Emotional exhaustion and turnover intention

Emotional exhaustion, the primary symptom of burnout (Maslach et al., 2001), poses significant risks not only to employees' physical and emotional health but also to business success. Extensive literature on emotional exhaustion indicates its association with unfavorable employment outcomes, including high turnover intention (Reb et al., 2017; Saleh, Sarwar, et al., 2022; Wen et al., 2020). The intensity of work within an organization is a known stressor that is strongly linked to emotional exhaustion and contributes to low job satisfaction (Elçi et al., 2018). This means overburdened employees may experience emotional exhaustion (S. H. Chan et al., 2015; Nasharudin et al., 2020; Suifan et al., 2020), leading to a decline in their service quality, and subsequently, an increase in their job turnover intention (Upadyaya & Salmela-Aro, 2020). Considering the negative impact of employees' emotional exhaustion on their withdrawal behavior, this study proposed the following hypothesis:

H1. Emotional exhaustion is positively related to early career employees' turnover intention.

2.4. Ethical leadership, emotional exhaustion, and turnover intention

The success of teams and organizations is significantly influenced by workplace leaders (Riisla et al., 2021). In this regard, ethical leadership is defined as the "display of behaviors consistent with appropriate norms, which are visible through the leader's actions and relationships" (Brown et al., 2005, p. 120). The emphasis on ethical leadership arises from the recognition that ethics play a crucial role in effective leadership, as leaders are responsible for promoting ethical climates and behavior within the organization (Brown & Treviño, 2006). Ethical leaders are known for their honesty, fairness, and trustworthiness, and they play a pivotal role in defining and articulating corporate values that foster a positive environment for employees. More beneficially, these leaders invest time in engaging and encouraging employees to make the latter feel consistently acknowledged and valued. Such actions enable two-way communication, reinforcement, and decision-making (Neubert et al., 2009). As a result, working with ethical leaders empowers individuals and fosters confidence, leading to greater involvement and a sense of value in the work unit (Mehmood et al., 2021).

According to the SET (Blau, 1964; Cropanzano & Mitchell, 2005), ethical leaders influence their employees through exchange learning, serving as an intermediary through which followers contribute to desired outcomes for the organization (Pucic, 2015) and engage in ethical actions (Hoch

et al., 2018). Kim Siew's study (Kim Siew, 2017) pointed out that supervisors are responsible for directing their subordinates' work and making key decisions that influence their actions. When employees receive positive initiating actions from their supervisors, they respond with more positive reciprocations (e.g., staying with the organization) or less negative reciprocations (e.g., turnover intention) (Cropanzano et al., 2017). This creates a trickle-down effect in firms from top management teams to lower-level employees (O'Keefe et al., 2019). In this manner, by treating people fairly and respectfully, ethical leadership establishes trust and thereby increases employee retention (De Hoogh & Den Hartog, 2008). Conversely, low levels of ethical leadership may lead to higher turnover intention and emotional exhaustion (Okpozo et al., 2017). Based on these justifications, this study posits that a lack of ethical leadership mediates the relationship between emotional exhaustion and turnover intention. Accordingly, the following hypotheses were postulated:

H2a. Early-career employees' emotional exhaustion is negatively related to ethical leadership.

H2b. Ethical leadership is negatively related to early-career employees' turnover intention.

H2c. Ethical leadership mediates the relationship between early-career employees' emotional exhaustion and turnover intention.

2.5. Self-interest ethical climate as a moderator

Among the various antecedents of employee conduct, the concept of ethical climate has emerged as a significant factor (Kuenzi et al., 2020; Martin & Cullen, 2006; Newman et al., 2017). Victor and Cullen (1988) defined ethical climate as "prevailing perceptions of typical organizational activities and procedures with ethical meaning" (p. 101). They presented a taxonomy of nine different types of ethical climates, each formed based on employees' personal desires and career aspirations. This is in line with Cheng and Wang's (2015) suggestion that "ethical climate may not be regarded as a whole in the study and should be divided down into several sub-dimensions for assessment to better understand its internal mechanism" (p. 640). Ethical climates in organizations guide employees with behavioral norms, helping them distinguish what is acceptable in the workplace. Positive ethical climates are associated with desirable outcomes such as job satisfaction and organizational commitment, while negative ethical climates are linked to undesirable outcomes like turnover intention (Decoster et al., 2019) or emotional exhaustion.

Self-interest (under egoistic criterion) and individual locus of control characterize the self-interest ethical climate, where individuals prioritize their own needs and preferences, such as personal gain or self-defense. Accordingly, an organizational self-interest ethical climate promotes an individualistic and independent approach to ethical challenges within the organization (Teresi et al., 2019). For example, early studies by Victor and Cullen (1988) suggested that telemarketing sales agents' organizational commitment is relatively low when each person's sales and commissions are independent, such that they primarily focus on their self-interests. In such a climate, employees tend to protect and reward the interests of their in-group members, and those who exhibit corrupt intentions and behaviors tend to display a higher commitment to unethical objectives (Rabl, 2011). Moreover, in a self-interest climate, employees may evade personal accountability for the consequences of their unethical behavior (S. H. J. Chan & James, 2020), which can lead to emotional exhaustion and subsequent coping withdrawal behaviors as employees seek to conserve their remaining resources (Gupta & Srivastava, 2020; Pooja et al., 2016).

To foster positive workplace outcomes, organizations should focus on flexible human capital arrangements and adapt to changing environments. In this regard, ethical leadership plays a crucial role in shaping an organization's ethical standards through procedures, processes, and policies, influencing employees' perceptions of the ethical climate (Kuenzi et al., 2020; Ogunfowora et al., 2021; Zhang et al., 2017). Perceptions of a high self-interest ethical climate signal to employees that they are not valued members of the organization, which may increase the impacts

of low ethical leadership and high emotional exhaustion on their intention to turnover. Based on the preceding discussion, this study hypothesized the following:

H3. The self-interest ethical climate moderates the positive relationship between early-career employees' emotional exhaustion and turnover intention, such that the relationship is stronger at higher levels of the self-interest climate.

H4. The self-interest ethical climate moderates the negative relationship between ethical leadership and early-career employees' turnover intention, such that the relationship is weaker at higher levels of the self-interest climate.

Figure 1 depicts the conceptual framework of the study.

3. Methodology

3.1. Sampling and data collection

This study followed the positivism paradigm and deductive approach. Quantitative data was collected through a questionnaire survey administered among early-career employees of information technology SMEs in the state of Selangor, Malaysia. This industry was chosen because organizations seeking young technical talent are expected to provide beneficial organizational conditions that can attract and retain such talent. Selangor was selected as it houses the highest number (19.8%) of SMEs in Malaysia according to the Department of Statistics Malaysia (DOSM, 2016). The DOSM (2020) reported a total of 248,165 SMEs (229,876 small and 18,289 medium-sized) in Malaysia as of 2020.

Due to the lack of a specific sampling frame and exact number of employees in the target category, the study employed a non-probability sampling technique, specifically convenience sampling, to select early-career employees in tech SMEs in Selangor. Prior to data collection, a power analysis was conducted using G*Power 3.1.9.4 software (Faul et al., 2007) to determine the required sample size for the proposed structural model (Figure 1). The analysis indicated that a minimum of 129 observations were needed to achieve 95% statistical power for a medium effect size (0.15) at a significance level of 5% (0.05). To ensure an adequate response rate, researchers distributed 516 (i.e., four times the required sample size) questionnaires both physically and virtually.

Figure 1. Conceptual model.

Source: Developed by authors

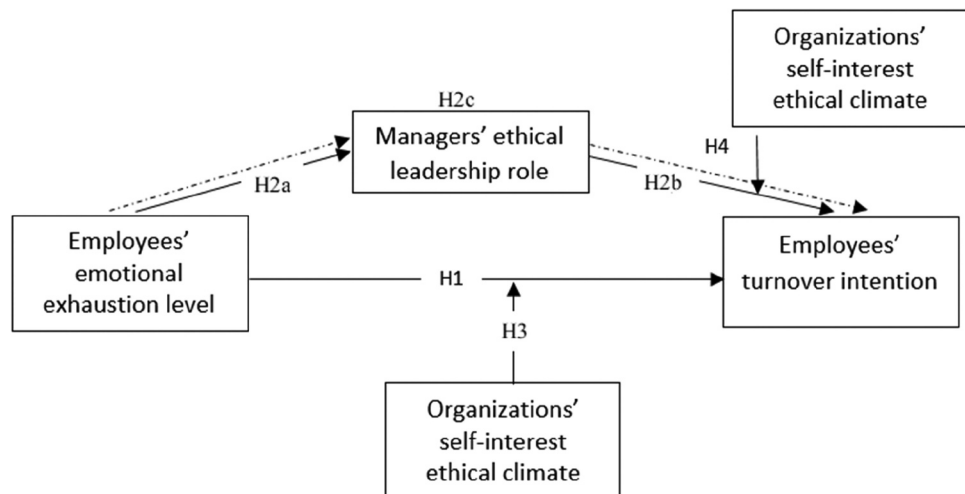

Table 1. Demographic profile of the respondents

Variable	Categories	Percentage	Mean	Std. Deviation
Gender	Male	40.4	1.6	0.492
	Female	59.6		
Age	18 to 25	32.8	1.26	0.863
	26 to 35	67.2		
Ethnicity	Malay	48.8	1.51	1.169
	Chinese	26.7		
	Indian	24.1		
No. of years in present position	2 Years or less	29.2	1.15	0.97
	2 to 4 Years	37.3		
	5 to 7 Years	12.3		
No. of years under present manager	2 Years or less	40.2	0.82	0.839
	2 to 4 Years	40.4		
	5 to 7 Years	13.8		

Source: Outcome from SPSS for descriptive analysis

The physical survey was administered by visiting SMEs and startup fairs, while the online Google Form survey was shared on LinkedIn and social media groups for Malaysian startups and entrepreneurs. To choose the sample SMEs for physical data collection, data was acquired from the Department of Statistics Malaysia and SME Corporation Malaysia. Permission to conduct the research was sought from top management in the chosen SMEs. The questionnaire, along with a cover note highlighting the confidentiality of respondents' information, was sent to the human resource personnel, following Dillman's (2000) recommendation. They then took responsibility for collecting data from the employees and set a deadline for the questionnaires' return. A cover page was also included in the online version of the questionnaire. All respondents were informed that participation in the survey was voluntary, and that they could opt out at any time. Through screening questions, the survey was administered only to early-career tech SME employees who had worked under their current managers for six months or more, as suggested by Yukl et al. (2019). These criteria not only met the research objectives, but also ensured that the sampled employees have had the opportunity to observe the behavior of their leaders and organizations.

The completed surveys were collected within a two-month timeframe, ending in April 2022. A total of 306 responses were ultimately received, out of which 243 were deemed usable. This sample size is considered adequate, as Siew et al. (2023) recent study on job hopping in Malaysian SMEs also attained 203 employees' responses. The data was then analyzed using SPSS 24 and SmartPLS 4. Table 1 provides an overview of the respondents' profile.

3.2. Measurements

A structured questionnaire was developed to assess the study variables and gather demographic information, including gender, age, ethnicity, highest education level, number of years in the current position, and number of years under the current manager. The variables were measured using validated scales from previous research (Leiter & Schaufeli, 1996). The survey items were kept in their original English form.

For assessing emotional exhaustion, respondents were asked to rate four items on how they manage their own emotions at work, with scale markers from "1 = Never" to "5 = Always." The Cronbach's alpha for this scale was 0.804. Turnover intention was assessed using a three-item scale (Kelloway et al., 1999) rated on a five-point Likert scale, ranging from "1 = Strongly Disagree" to "5 = Strongly Agree." It measured employees' desire to leave the organization based on perceived job pressure, with a Cronbach's alpha of 0.806. Next, the 10-item scale for ethical leadership

was adapted from Brown et al. (2005) and rated on a five-point Likert scale, from “1 = Strongly Disagree” to “5 = Strongly Agree.” The Cronbach’s alpha for this scale was 0.868. Finally, self-interest ethical climate was measured using a five-item scale adapted from Cullen et al. (1993) Ethical Climate Questionnaire, rated on a 5-point Likert scale ranging from “1 = Mostly False” to “5 = Mostly True.” Due to reliability and validity concerns in the Malaysian context, two egoism (self-interest) questions were excluded from the self-interest ethical climate scale. The Cronbach’s alpha for this scale was 0.704.

To validate the appropriateness of the factor analysis for the 20 items, the Kaiser-Meyer-Olkin (KMO) test and Bartlett’s Test of Sphericity were employed. The KMO test yielded an overall measure of sampling adequacy of 0.762 (>0.50), and Bartlett’s test provided support for the factor analysis with a value of 2307.567, $df=190$, and significance at $p<0.01$. All items also showed loadings greater than 0.60, as displayed in Table 3.

3.3. Control variables

This study incorporated control variables to account for participants’ demographics that could be potential antecedents of employee turnover intention, specifically age and ethnicity. Prior research has indicated that individual factors, including age, gender, employment tenure, and education, can impact employee turnover intention behaviors (e.g., Cohen et al., 2016). Thus, by including age and ethnicity as control variables, the study aimed to explore potential differences in turnover intention among respondents of different age and ethnic groups.

3.4. Common method bias

To address potential common method bias (CMB), this study implemented several strategies based on the recommendations of Podsakoff et al. (2012) and Tehseen et al. (2017). Firstly, participants were assured that their responses would remain private and confidential, and that the data would be used solely for research purposes. Secondly, the survey was designed in a way that the measurements were presented on separate pages, and explicit instructions were given for participants to read each statement carefully and respond honestly, emphasizing that the data would only be used for research purposes. Item ambiguity was minimized by defining unfamiliar terms and using specific questions (Tourangeau et al., 2000).

Additionally, to further assess the presence of CMB, Harman’s single-factor test was conducted, involving a principal component factor analysis that included all major constructs. This test was performed as a post-hoc analysis after data collection to examine whether a single factor accounted for most of the variance in the data (Chang et al., 2010). The results indicated that 38% of the data variance was explained by a single factor, which is less than the threshold of 50% (Fuller et al., 2016; Svensson et al., 2018). This suggests that common method variance was not a significant concern in this study.

4. Data analysis and results

A preliminary analysis of the study data was conducted using SPSS version 24.0, which included examining missing values, outliers, means, medians, standard deviations, and normality assumptions. No missing values and outliers were found, while skewness values ranged from -2.214 to 0.289 and kurtosis values ranged from -1.284 to 7.433 . According to Kline (2011), the results indicated that non-normality did not severely affect the parameter estimation and standard deviation of the model since all absolute skew values were smaller than eight, and kurtosis was smaller than 10.

Table 1 presents the demographic profile of the respondents. The respondents consisted of 40.4% males and 59.6% females. Among the early-career employees, 32.8% fell under the age group of 18 to 25, while 67.2% were aged between 26 and 35. Regarding ethnicity, the largest group represented was Malay (48.8%), followed by Chinese (26.7%) and Indian (24.1%). The majority of early-career employees had been in their current position for two to four years

(37.3%), and a similar percentage (40.4%) had been working under their current manager for two to four years.

4.1. Descriptive statistics and correlations

The study utilized SPSS 24.0 software to calculate descriptive statistics and correlations. Table 2 presents the means, standard deviations, and Pearson correlation values for all key variables. As shown in Table 2, early-career employees' emotional exhaustion is positively correlated with their turnover intention ($r = .42, p < .01$), negatively correlated with ethical leadership ($r = -.19, p < .01$), and positively correlated with the self-interest ethical climate ($r = .45, p < .01$). Ethical leadership was found to be negatively correlated with both turnover intention ($r = -.22, p < .01$) and the self-interest ethical climate ($r = -.32, p < .01$). Additionally, early-career employees' gender appears to be positively correlated with organizations' self-interest ethical climate ($r = .19, p < .01$). On the other hand, employees' ethnicity is positively correlated with their level of emotional exhaustion ($r = .16, p < .01$). Lastly, early-career employees' turnover intention was shown to be negatively correlated with their number of years working in the same position ($r = -.17, p < .01$), but positively correlated with the self-interest ethical climate ($r = .18, p < .01$) and emotional exhaustion ($r = .42, p < .01$). These results provided initial support for the hypotheses.

4.2. Structural equation modeling

As the data deviated from the assumption of multivariate normality, partial least squares structural equation modeling (PLS-SEM) was employed to test the hypotheses. Specifically, bootstrapping with 5000 resamples and a 95% bias-corrected confidence interval was employed to estimate the model (Byrne, 2016). The first stage of PLS-SEM is the assessment of the measurement model to ascertain reliability and validity, while the second stage is the assessment of the structural model for hypothesis testing.

4.2.1. Measurement model analysis results

In the measurement model analysis, the constructs were assessed for internal consistency reliability, convergent validity, and discriminant validity, following the standard evaluation criteria proposed by Hair et al. (2019) and Sarstedt et al. (2020). Table 3 presents the results of the evaluation for reliability and convergent validity using factor loadings, composite reliability (CR), and average variance extracted (AVE).

All the item loadings exceeded the recommended value of 0.6 (Chin et al., 2008), indicating satisfactory convergent validity. The CR values for each latent construct also exceeded the recommended value of 0.7, further confirming the internal consistency reliability of the measurement model. Additionally, the AVE for each construct exceeded the suggested threshold of 0.5, which indicates that the latent constructs accounted for a substantial amount of variance in their respective indicators (Hair et al., 2017). This demonstrates the satisfactory convergent validity of the measurement model.

The second step involved assessing the discriminant validity through correlation (Table 4), which refers to the extent of differentiation between constructs in the measurement model (Rönkkö & Cho, 2022).

The Fornell and Larcker (1981) criterion was then applied to confirm discriminant validity. As presented in Table 5, the square root of AVE for each construct was higher than its correlation with other constructs, indicating acceptable discriminant validity.

Finally, the Heterotrait-Monotrait (HTMT) method proposed by Henseler et al. (2015) was utilized to confirm discriminant validity. According to this method, discriminant validity is established if the HTMT values are below the thresholds of 0.90 (Henseler et al., 2015) or 0.85 (Kline, 2015), which is

Table 3. Convergent validity and reliability of constructs

Constructs	Items	Loadings	CR	AVE
Emotional Exhaustion	Working all day is really a strain for me	0.77	0.862	0.612
	I feel emotionally drained from my work	0.88		
	I feel fatigued when I get up in the morning and have to face another day on the job	0.82		
	I feel used up at the end of the workday	0.64		
Self-Interest Ethical Climate	In this company, people are mostly out for themselves	<i>Dropped</i>	0.816	0.563
	There is no room for one's own personal morals or ethics in this company	0.64		
	In this company, people protect their own interest above other considerations	0.96		
	People in this company are very concerned about what is best for themselves	0.61		
	It is expected that each individual is cared for when making decisions here	<i>Dropped</i>		
Ethical Leadership	My manager ...		0.899	0.521
	Listens to what employees have to say	0.78		
	Disciplines employees who violate ethical standards	0.62		
	Conducts his/her personal life in an ethical manner	0.68		
	Has the best interests of employees in mind	0.75		
	Makes fair and balanced decisions	0.65		
	Can be trusted	0.73		
	Discusses business ethics or values with employees	0.87		
	Defines success not just by results but also the way that they are obtained	0.70		
	Sets an example of how to do things the right way in terms of ethics	0.71		
	When making decisions, asks "what is the right thing to do?"	0.66		
Turnover Intention	I plan on leaving my job within the next year	0.90	0.886	0.722
	I will likely actively look for a new job in the next year	0.82		
	I often think about quitting	0.83		

Source: Outcome from SmartPLS 4

Table 2. Pearson correlations

Constructs	Correlations											
	M	STDV	1	2	3	4	5	6	7	8	9	
Gender	1.52	.501	1									
Employee's Age	1.07	.857	-.133*	1								
Employee's Ethnicity	1.88	.788	.336**	.009	1							
No. of years in present position	1.09	.907	-.033	.479**	-.146*	1						
No. of years with present manager	.77	.795	-.176**	.342**	-.220**	.629**	1					
Self-Interest Ethical Climate	2.50	.870	.196**	.030	.224**	.247**	.266**	1				
Ethical Leadership	3.54	.844	-.062	.114	-.139*	.106	.038	-.0321	1			
Emotional Exhaustion	3.04	.831	-.153*	.007	.169**	-.149*	-.086	.452	-.198**	1		
Turnover Intention	3.04	1.201	-.082	-.163*	.071	-.199**	.188**	.188**	-.226**	.421**	1	

*Correlation is significant at the 0.05 level (2-tailed).

**Correlation is significant at the 0.01 level (2-tailed).

Source: Outcome from SPSS for Pearson correlations analysis

Table 4. Discriminant validity assessment using correlation

Constructs	1	2	3	4	5	6	7
Age	1.000						
Emotional exhaustion	0.05	0.783					
Ethical climate	0.012	-0.194	0.621				
Ethical leadership	0.118	-0.311	0.513	0.708			
Ethnicity	0.042	-0.157	-0.232	-0.153	1.000		
Turnover intention	-0.142	0.438	-0.348	-0.337	0.102	0.850	
Ethical climate x Ethical leadership	0.029	-0.008	0.002	-0.433	0.048	0.119	
Ethical climate x Emotional exhaustion	0.024	-0.091	-0.05	-0.007	0.005	-0.188	-0.148

Values on the diagonal (bolded) are square root of the AVE while the off-diagonals are correlations.

Source: Outcome from SmartPLS 4.

proven in Table 6. Thus, correlation, HTMT and the Fornell and Larcker criteria demonstrate that the constructs in the study had acceptable discriminant validity.

4.2.2. Structural model analysis results

After establishing the reliability and validity of the constructs, the structural model assessment was conducted, wherein path relationships were analyzed to examine the direct and indirect relationships among the variables (see Table 7 for results). The R², beta coefficient, and corresponding t-values were computed using the bootstrapping procedure with 5000 resamples (Hair

Table 5. Discriminant validity assessment using Fornell and Larcker criteria

Constructs	Emotional exhaustion	Ethical climate	Ethical leadership	Turnover intention
Emotional exhaustion	0.783			
Ethical climate	-0.194	0.621		
Ethical leadership	-0.311	0.513	.708	
Turnover intention	0.438	-0.348	-.337	0.85

Source: Outcome from Smart-PLS4.

Table 6. Discriminant validity assessment using HTMT criterion

Constructs	Emotional exhaustion	Ethical climate	Ethical leadership	Turnover intention
Emotional exhaustion				
Ethical climate	0.348			
Ethical leadership	0.279	0.61		
Turnover intention	0.509	0.408	.342	

Source: Outcome from SmartPLS 4.

Table 7. Hypothesis testing results

Hypothesis	Relationships	Std. beta	SD	t-value	p-value	Decision	f^2	2.50%	97.50%
H1	Emotional Exhaustion → Turnover Intention	0.492	0.062	9.228	0.001	Significant	0.245	0.285	0.53
H2	Emotional Exhaustion → Ethical Leadership → Turnover Intention	0.062	0.047	3.268	0.003	Significant		0.029	0.097
H3	MOD_EE*SIEC → Turnover Intention	0.124	0.043	2.893	0.002	Significant	0.379	0.040	0.206
H4	MOD_EL*SIEC → Turnover Intention	-0.059	0.055	1.068	0.286	Not Significant	0.116	-0.165	0.048
Control variables	Age → Turnover Intention	-0.154	0.054	2.871	0.004	Significant	0.137	-0.256	-0.035
	Ethnicity → Turnover Intention	0.148	0.063	2.337	0.020	Significant	0.163	0.032	0.276

et al., 2013). Additionally, effect sizes (f^2) were reported, indicating that age and ethnicity have relatively small and medium effects, respectively, on turnover intention.

First, H1 tested the direct effect of emotional exhaustion on turnover intention. The results indicated a significant positive impact of early-career employees' emotional exhaustion on their turnover intention with $R^2 = 0.306$, ($\beta = 0.492$, $t = 9.228$, $p < 0.001$), thus supporting H1. Next, H2 examined the mediating role of ethical leadership in the relationship between emotional exhaustion and turnover intention. The bootstrapping approach suggested by Hair et al. (2017) was employed for mediation analysis, as it can assess the sampling distribution of statistics. A significant mediation effect occurs when the indirect influence of an independent variable on a dependent variable through an intervening variable is statistically significant (Preacher & Hayes, 2008). The results revealed that when ethical leadership is highly present in the workplace, emotional exhaustion among employees is low with $R^2 = 0.097$ ($\beta = 0.063$, $t = 3.268$, $p < 0.003$). Moreover, high ethical leadership in the workplace is associated with a low likelihood of employee turnover intention. This study found that ethical leadership serves as a major mechanism connecting employees' emotional exhaustion and their turnover intention, aligning with the propositions of the SET. Thus, H2 was supported, indicating that ethical leadership fully mediates the relationship between emotional exhaustion and turnover intention.

4.2.3. Moderation analysis results

For H3, moderation testing was conducted to examine whether the self-interest ethical climate moderates the association between emotional exhaustion and turnover intention. The bootstrapping analysis indicated a significant moderating effect ($\beta = 0.124$, $t = 2.893$, $p < 0.001$), while the f^2 value implied a medium effect on the relationship. These results suggest that when early-career employees perceive a high self-interest ethical climate, their emotional exhaustion levels lead to higher turnover intention (see Figure 2). The R^2 change of 0.306 with the addition of the interaction term (EE*SIEC) further confirmed the presence of a moderation effect, as there was an increase in the variance explained by the independent factor in the dependent factor after introducing the moderator variable. Hence, H3 was supported. As for H4, the analysis revealed that there was an insignificant difference in the relationship between ethical leadership and employees' turnover intention across high and low self-interest ethical climates ($\beta = -0.059$, $t = 1.068$, $p > 0.001$). Thus, H4 was not supported.

Figure 3 illustrates the full structural model of this study.

Figure 2. The moderating effect of the self-interest ethical climate on the relationship between emotional exhaustion and turnover intention.

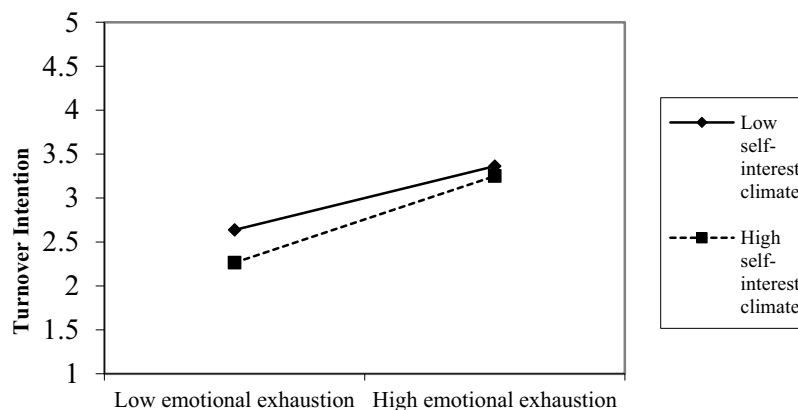
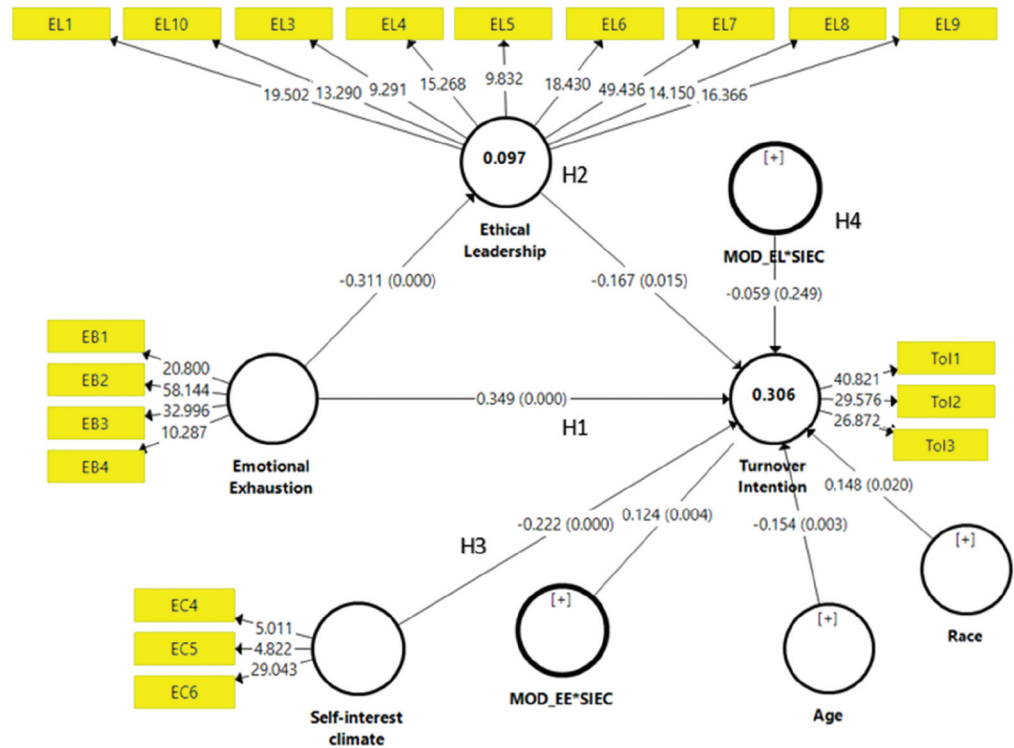

Figure 3. Structural model.

Source: Outcome from SmartPLS 4



5. Discussion

The main objective of this study was to examine the relationship between early-career employees' emotional exhaustion and their turnover intention, while considering the mediating role of ethical leadership. Additionally, the study focused on the moderating influence of the self-interest ethical climate, providing a more comprehensive scope for contribution to the existing literature. By investigating the dynamic nature of the workplace environment, this research aimed to identify the consequences of the self-interest climate on employees' emotional exhaustion and ethical leadership and their impact on workplace outcomes. Four hypotheses were formulated based on the study's objectives, and the results obtained through PLS-SEM supported three of them. The key findings are explained in the following sub-sections.

5.1. Main findings

The findings of this study contribute to the existing body of knowledge by providing empirical evidence on the significance of emotional exhaustion in triggering early-career SME employees' turnover intention, thereby answering the first research question. Addressing the second research question about the mediating role of ethical leadership between emotional exhaustion and turnover intention, the results suggest that low levels of ethical leadership can make highly exhausted employees form the intention to leave the organization.

The findings align with the research of Bedi et al. (2016) and Dust et al. (2018), which suggest that when employees perceive their leaders as ethical, they are more likely to feel competent, effective, and flexible in their work. Employees who work under ethical leaders also experience higher levels of confidence, purpose, influence, and control pertaining to their job. These positive perceptions reduce emotional exhaustion among employees, leading to a reduction in chronic stress, improved workplace interactions and coping abilities, and ultimately, stronger commitment to stay with the organization (Plantiveau et al., 2018; Riisla et al., 2021). Furthermore, the presence of supervisory support creates a meaningful alignment between employees' beliefs and organizational standards, resulting in favorable work

organizational outcomes. By verifying the mediating role of ethical leadership between early-career employees' emotional exhaustion and turnover intention, this study adds valuable insights to the literature and sheds light on the importance of ethical leadership in mitigating emotional exhaustion and fostering employee retention in tech SMEs in Malaysia.

The study also addressed the third research question regarding SMEs' self-interest ethical climate as a moderator of the effects of emotional exhaustion and ethical leadership on turnover intention. The focus on the self-interest ethical climate is a response to the call made by Barattucci et al. (2021) to explore organizational factors that may influence employee turnover intention. This study's findings establish how the self-interest ethical climate of organizations can act as a catalyst towards early-career employees' turnover intention. The findings align with Okpozo et al. (2017) and Paterson and Huang (2018) in demonstrating that the presence of a high self-interest ethical climate can contribute to increased emotional exhaustion among employees, leading to higher turnover intention.

The study supports the notion that a self-interest ethical climate may encourage an individualistic and independent attitude towards dealing with ethical issues, focusing on personal well-being and power (Barattucci et al., 2021). Such a negative and stressful workplace environment can deplete organizational resources, ultimately leading to emotional exhaustion (Plantiveau et al., 2018; Riisla et al., 2021). In contrast, organizations with favorable ethical environments have good moral and ethical guidelines, thus alleviating employees' emotional exhaustion (O'Keefe et al., 2019; Paterson & Huang, 2018).

However, the results did not support the hypothesis that managers' ethical leadership, in conjunction with a self-interest ethical climate, would affect early-career employees' turnover intention. Nevertheless, in the presence of high self-interest ethical climate, ethical leadership may still play a role in reducing turnover intention by creating corporate norms and ethical standards, which can positively influence employee work decisions.

Moreover, this study contributes to the understanding that age and ethnicity inequalities at the workplace can influence communication and networking patterns, subsequently affecting organizational phenomena like turnover (Calderón-Milán et al., 2020; Cohen et al., 2016; Hossain et al., 2018). The current findings highlight the significant effect of early-career employees' age and ethnicity on their turnover intention, especially in the presence of a self-interest ethical climate. This further emphasizes the importance of considering organizational factors and the role of ethical leadership in managing turnover among young employees in the early stages of their career.

5.2. Theoretical and practical contributions

This study holds significant theoretical and practical implications. Theoretically, it contributes new insights to the turnover intention literature by highlighting emotional exhaustion as a previously overlooked antecedent. The study also adds to the existing knowledge on ethical leadership and its outcomes by examining its mediating influence between emotional exhaustion and turnover intention. Moreover, the study enriches the behavioral outcome literature in the SME setting, demonstrating that the presence of an ethical leader in an SME can prevent the formation of turnover intention. Another key contribution of this research is its fresh insight into the moderating impact of the self-interest ethical climate on the relationship between emotional exhaustion and turnover intention, in line with Paterson and Huang (2018). Lastly, the results support and extend the relevance of the SET and COR theory in explaining the link between turnover intention and its antecedents.

Practically, this study's findings suggest that supervisors and line managers should work collaboratively to address job resource perceptions, considering that they may vary among different positions. This collaboration can offer a more comprehensive understanding of possibilities within the work environment. Consistent with Dust et al. (2018), supervisors should take action when employees exhibit signs of exhaustion or psychological strain to alleviate job pressures and foster social exchange processes. Organizations can also implement training modules and coaching sessions to help employees identify and manage work-related stressors through relevant coping strategies. Additionally, as mentioned by

Asad (2020), understanding the significance of human resource practices can influence organizational commitment and impact employee turnover intention. Managers should therefore focus on fostering conditions that allow employees to share knowledge within their work units, encouraging a sense of ownership and reducing emotional exhaustion. Organizational commitment and support are indeed key in creating a healthy and safe working environment, which can enhance overall employee well-being and prevent emotional exhaustion. In conclusion, the study's findings offer valuable insights into the interplay between emotional exhaustion, ethical leadership, self-interest ethical climate, and turnover intention.

5.3. Limitations and future research

While this study provides significant findings, it also has some limitations. Firstly, the study employed a cross-sectional design, which may limit the ability to draw causal conclusions about the relationships between the variables. Future research should consider implementing time-lagged designs to observe how the pattern of relationships between ethical leadership, organizational ethical climate, emotional exhaustion, and turnover intention unfolds over time, allowing for a better understanding of how changes in the ethical climate may influence changes in ethical leadership and employee outcomes.

Secondly, the data for this study was gathered from only one developing country (i.e., Malaysia), with a specific focus on early-career employees from information technology SMEs in the Selangor state. Thus, the findings may not be easily generalized to other settings. Including data from other cultural and industry contexts would provide a more comprehensive view of the relationships examined in the study. In fact, conducting in-depth research on early-career employees in various industries would be valuable. Early-career employees often encounter unique challenges in dealing with the external environment, internal groups, and other individuals, which can contribute to emotional exhaustion and ultimately lead to turnover intention. Examining these factors in different industries could provide valuable insights into effective strategies to manage and reduce turnover intention among early-career employees.

Thirdly, the current study's population consisted of employees from specific ethnicities in Malaysia (Malay, Chinese, Indian). To gain a more nuanced understanding, future studies could compare these three ethnic groups and focus on each group's respective levels and antecedents of turnover intention. Finally, in future research, it may be beneficial to use additional measures, such as depersonalization or decreased personal accomplishment, to assess burnout, since "emotional exhaustion alone is not a predictor of burnout" (Maslach & Leiter, 2018). Including such measures could provide a more comprehensive assessment of burnout among early-career employees. Future research could also explore the effects of organizational assistance on early-career employees' emotional exhaustion in different work environments. Alternatively, other organizational climate types (e.g., local and cosmopolitan) (Cullen et al., 2003) can be incorporated as extensions of this research model.

6. Conclusion

This study has explored the relationship between early-career employees' emotional exhaustion and their turnover intention via the mediating role of ethical leadership. The findings indicate that there is a direct positive relationship between employees' emotional exhaustion and their turnover intention. Notably, the presence of an ethical leader has been found to link lower emotional exhaustion levels to weaker turnover intention. This is attributed to frequent interactions between the manager and the employee, fostering trust and improving performance. The presence of ethical leadership in the work unit cultivates a system of controlled accepted beliefs and appropriate judgments, which proves beneficial for both employees and organizations. Regarding the moderating effect of self-interest ethical climate, this study suggests that in the presence of a self-interest ethical climate, emotional exhaustion has a stronger impact on early-career employees' turnover intention. Drawing on the COR theory, this finding contributes to the literature by establishing that a self-interest ethical climate may worsen the detrimental effects of emotional exhaustion due to reduced resources.

Considering these results, the study emphasizes the importance of organizations creating an ethical climate for their employees as a means of enhancing their emotional well-being and retention. To achieve this, it is suggested that organizations adopt an ethical leadership style,

which can help build an organizational ethical climate and reduce turnover intention. By placing a strong emphasis on ethical leadership and promoting an ethical work environment, organizations can create a positive atmosphere that supports employees' emotional well-being and job satisfaction, ultimately contributing to lower turnover rates.

Funding

This work was supported by the Research Management Centre of Multimedia University, Cyberjaya, Malaysia.

Author details

Tajneen Affnaan Saleh¹

Abdullah Sarwar¹

E-mail: abdullah.sarwar@mmu.edu.my

Nasreen Khan¹

ORCID ID: <http://orcid.org/0000-0002-8000-2000>

Mosab I. Tabash²

E-mail: mosab.tabash@auu.ac.ae

ORCID ID: <http://orcid.org/0000-0003-3688-7224>

Mohammad Imtiaz Hossain¹

ORCID ID: <http://orcid.org/0000-0002-9637-3201>

¹ Faculty of Management, Malaysia Multimedia University, Cyberjaya, Malaysia.

² College of Business, Al Ain University, Al Ain, UAE.

Disclosure statement

No potential conflict of interest was reported by the author(s).

Additional information

No additional information is available for this paper.

Authors' contribution statements

Tajneen Affnaan Saleh: Conceptualization and execution of the research; Methodology; Software; Data curation; Writing of original draft.

Abdullah al Mamun: Conceptualization; Supervision; Methodology; Software; Data curation; Discussion of research framework.

Nasreen Khan: Review; Supervision; Editing; Suggestions for improvement.

Mosab I. Tabash: Conceptualization; Methodology; Discussion of the findings; Review.

Mohammad Imtiaz Hossain: Methodology, Writing and Editing; Review.

Data availability statement

Data included in article.

Citation information

Cite this article as: Does emotional exhaustion influence turnover intention among early-career employees? A moderated-mediation study on Malaysian SMEs, Tajneen Affnaan Saleh, Abdullah Sarwar, Nasreen Khan, Mosab I. Tabash & Mohammad Imtiaz Hossain, *Cogent Business & Management* (2023), 10: 2242158.

References

- Ain, N. U., Azeem, M. U., Sial, M. H., & Arshad, M. A. (2022). Linking knowledge hiding to extra-role performance: The role of emotional exhaustion and political skills. *Knowledge Management Research and Practice*, 20(3), 367–380. <https://doi.org/10.1080/14778238.2021.1876536>
- Allam, Z., Asad, M., Ali, N., & Malik, A. (2022). Bibliometric analysis of research visualizations of knowledge aspects on burnout among teachers from 2012 to January 2022. *Proceedings of the 2022 International Conference on Decision Aid Sciences and Applications (DASA)* (pp. 126–131). IEEE. <https://doi.org/10.1109/DASA54658.2022.9765200>

- Asad, M. (2020). Human resource practices and employee turnover intentions: Do organizational commitment mediates and social support moderates the relationship? *International Journal of Psychosocial Rehabilitation*, 24(7), 5685–5695. <https://doi.org/10.37200/IJPR/V24I7/PR27527>
- Babalola, M. T., Stouten, J., Camps, J., & Euwema, M. (2019). When do ethical leaders become less effective? The moderating role of perceived leader ethical conviction on employee discretionary reactions to ethical leadership. *Journal of Business Ethics*, 154(1), 85–102. <https://doi.org/10.1007/s10551-017-3472-z>
- Babalola, M. T., Stouten, J., & Euwema, M. (2016). Frequent change and turnover intention: The moderating role of ethical leadership. *Journal of Business Ethics*, 134(2), 311–322. <https://doi.org/10.1007/s10551-014-2433-z>
- Barattucci, M., Teresi, M., Pietroni, D., Iacobucci, S., Lo Presti, A., & Pagliaro, S. (2021). Ethical climate(s), distributed leadership, and work outcomes: The mediating role of organizational identification. *Frontiers in Psychology*, 11(February), 1–11. <https://doi.org/10.3389/fpsyg.2020.564112>
- Bedi, A., Alpaslan, C. M., & Green, S. (2016). A meta-analytic review of ethical leadership outcomes and moderators. *Journal of Business Ethics*, 139(3), 517–536. <https://doi.org/10.1007/s10551-015-2625-1>
- Benevene, P., Dal Corso, L., De Carlo, A., Falco, A., Carluccio, F., & Vecina, M. L. (2018). Ethical leadership as antecedent of job satisfaction, affective organizational commitment and intention to stay among volunteers of non-profit organizations. *Frontiers in Psychology*, 9(NOV), 1–17. <https://doi.org/10.3389/fpsyg.2018.02069>
- Black, A. (2010). Gen Y: Who they are and how they learn. *Educational Horizons*, 88(2), 92–101. 0013-175X.
- Blau, P. M. (1964). *Exchange and power in social life*. John Wiley.
- Brown, M. E., Treviño, L. K., & Harrison, D. (2005). Ethical leadership: A social learning perspective for construct development and testing. *Organizational Behavior and Human Decision Processes*, 97(2), 117–134. <https://doi.org/10.1016/j.obhdp.2005.03.002>
- Brown, M. E., & Treviño, L. K. (2006). Ethical leadership: A review and future directions. *The Leadership Quarterly*, 17(6), 595–616. <https://doi.org/10.1016/j.leaqua.2006.10.004>
- Byrne, B. M. (2016). *Structural equation modeling with AMOS: Basic concepts, applications, and programming* (3rd ed.). Routledge.
- Calderón-Milán, M. J., Calderón-Milán, B., & Barba-Sánchez, V. (2020). Labour inclusion of people with disabilities: What role do the social and solidarity economy entities play? *Sustainability*, 12(3), 1079. <https://doi.org/10.3390/su12031079>
- Chang, S. J., VanWitteeloostuijn, A., & Eden, L. (2010). From the editors: Common method variance in international business research. *Journal of International Business Studies*, 41(2), 178–184. <https://doi.org/10.1057/jibs.2009.88>
- Chan, S. H. J., & James, M. (2020). Impact of politics on emotional exhaustion, satisfaction and turnover intention. *Anatolia*, 31(4), 591–604. <https://doi.org/10.1080/13032917.2020.1802309>

- Chan, S. H., Wan, Y. K. P., & Kuok, O. M. (2015). Relationships among burnout, job satisfaction, and turnover of casino employees in Macau. *Journal of Hospitality Marketing & Management*, 24(4), 345–374. <https://doi.org/10.1080/19368623.2014.911712>
- Cheng, M. Y., & Wang, L. (2015). The mediating effect of ethical climate on the relationship between paternalistic leadership and team identification: A team-level analysis in the Chinese context. *Journal of Business Ethics*, 129(3), 639–654. <https://doi.org/10.1007/s10551-014-2189-5>
- Chiat, L. C., & Panatik, S. A. (2019). Perceptions of employee turnover intention by Herzberg's motivation-hygiene theory: A systematic literature review. *Journal of Research in Psychology*, 1(2), 10–15. <https://doi.org/10.31580/jrp.v1i2.949>
- Chin, W. W., Peterson, R. A., & Brown, P. S. (2008). Structural equation modelling in marketing: Some practical reminders. *Journal of Marketing Theory & Practice*, 16(4), 287e298. <https://doi.org/10.2753/MTP1069-6679160402>
- Cohen, G., Blake, R. S., & Goodman, D. (2016). Does turnover intention matter? Evaluating the usefulness of turnover intention rate as a predictor of actual turnover rate. *Review of Public Personnel Administration*, 36(3), 240–263. <https://doi.org/10.1177/0734371X15581850>
- Cosgrave, C., Maple, M., & Hussain, R. (2018). An explanation of turnover intention among early-career nursing and allied health professionals working in rural and remote Australia - findings from a grounded theory study. *Rural and Remote Health*, 18(3). <https://doi.org/10.22605/RRH4511>
- Costa, D. K., & Moss, M. (2018). The cost of caring: Emotion, burnout, and psychological distress in critical care clinicians. *Annals of the American Thoracic Society*, 15(7), 787–790. <https://doi.org/10.1513/AnnalsATS.201804-269PS>
- Cropanzano, R., Anthony, E. L., Daniels, S. R., & Hall, A. V. (2017). Social exchange theory: A critical review with theoretical remedies. *Academy of Management Annals*, 11(1), 479–516. <https://doi.org/10.5465/annals.2015.0099>
- Cropanzano, R., & Mitchell, M. S. (2005). Social exchange theory: An interdisciplinary review. *Journal of Management*, 31(6), 874–900. <https://doi.org/10.1177/0149206305279602>
- Cullen, J. B., Parboteeah, K. P., & Victor, B. (2003). The effects of ethical climates on organizational commitment: A two-study analysis. *Journal of Business Ethics*, 46(2), 127–141. <https://doi.org/10.1023/A:1025089819456>
- Cullen, J. B., Victor, B., & Bronson, J. W. (1993). The ethical climate questionnaire: An assessment of its development and validity. *Psychological Reports*, 73(2), 667–674. <https://doi.org/10.2466/pr0.1993.73.2.667>
- DeConinck, J. B. (2014). Outcomes of ethical leadership among salespeople. *Journal of Business Research*, 68(5), 1086–1093. <https://doi.org/10.1016/j.jbusres.2014.10.011>
- Decoster, S., Stouten, J., & Tripp, T. M. (2019). When employees retaliate against self-serving leaders: The influence of the ethical climate. *Journal of Business Ethics*, 168(1), 195–213. <https://doi.org/10.1007/s10551-019-04218-4>
- De Hoogh, A., & Den Hartog, D. (2008). Ethical and despotic leadership, relationships with leader's social responsibility, top management team effectiveness and subordinates' optimism: A multi-method approach. *The Leadership Quarterly*, 19(3), 297–311. <https://doi.org/10.1016/j.leaqua.2008.03.002>
- De Sousa Jabbour, A. B. L., Ndubisi, N. O., & Seles, B. M. R. P. (2020). Sustainable development in Asian manufacturing SMEs: Progress and directions. *International Journal of Production Economics*, 225(7), 1–14. <https://doi.org/10.1016/j.ijpe.2019.107567>
- Dillman, D. A. (2000). *Mail and internet surveys: The tailored design method* (2nd ed.). John Wiley and Sons.
- DOSM. (2016). Economic census 2016. <http://v2.dosm.gov.my/portal-main/census-surveys/Economy>
- DOSM. (2020). 2020 profile of SMEs. <https://www.oecd-ilibrary.org/sites/3bc2915cen/index.html?itemId=/content/component/3bc2915c-en>
- Dust, S. B., Resick, C. J., Margolis, J. A., Mawritz, M. B., & Greenbaum, R. L. (2018). Ethical leadership and employee success: Examining the roles of psychological empowerment and emotional exhaustion. *The Leadership Quarterly*, 29(5), 570–583. <https://doi.org/10.1016/j.leaqua.2018.02.002>
- Elçi, M., Yildiz, B., & Erdilek Karabay, M. (2018). How burnout affects turnover intention? The conditional effects of subjective vitality and supervisor support. *International Journal of Organizational Leadership*, 7(1), 47–60. <https://doi.org/10.33844/ijol.2018.60233>
- Faul, F., Erdfelder, E., Lang, A. G., & Buchner, A. (2007). G* Power 3: A flexible statistical power analysis program for the social, behavioral, and biomedical sciences. *Behavior Research Methods*, 39(2), 175–191. <https://doi.org/10.3758/BF03193146>
- Fornell, C., & Larcker, D. F. (1981). Evaluating structural equation models with unobservable variables and measurement error. *Journal of Marketing Research*, 18(1), 39. <https://doi.org/10.1177/002224378101800104>
- Fuller, C. M., Simmering, M. J., Atinc, G., Atinc, Y., & Babin, B. J. (2016). Common methods variance detection in business research. *Journal of Business Research*, 69(8), 3192–3198. <https://doi.org/10.1016/j.jbusres.2015.12.008>
- Giorgi, G., Lecca, L. I., Alessio, F., Finstad, G. L., Bondanini, G., Lulli, L. G., Arcangeli, G., & Mucci, N. (2020). COVID-19-R narrative ReviCOVIDew. *International Journal of Environmental Research and Public Health Review*, 17(December 2019), 1–22. <https://doi.org/10.3390/ijerph17217857>
- Griffeth, R. W., Hom, P. W., & Gaertner, S. (2000). A meta-analysis of antecedents and correlates of employee turnover: Update, moderator tests, and research implications for the next millennium. *Journal of Management*, 26(3), 463–488. <https://doi.org/10.1177/014920630002600305>
- Gross, J. J., & John, O. P. (2003). Individual differences in two emotion regulation processes: Implications for affect, relationships, and well-being. *Journal of Personality and Social Psychology*, 85(2), 348–362. <https://doi.org/10.1037/0022-3514.85.2.348>
- Guan, B., & Jepsen, D. M. (2020). Burnout from emotion regulation at work: The moderating role of gratitude. *Personality & Individual Differences*, 156 (October 2019), 109703. <https://doi.org/10.1016/j.paid.2019.109703>
- Gupta, P., & Srivastava, S. (2020). Work-life conflict and burnout among working women: A mediated moderated model of support and resilience. *International Journal of Organizational Analysis*, 29(3), 629–655. <https://doi.org/10.1108/IJOA-12-2019-1993>
- Haines, V. Y., Jalette, P., & Larose, K. (2010). The Influence of Human Resource Management Practices on Employee Voluntary Turnover Rates in the Canadian Non Governmental Sector. *ILR Review*, 63(2), 228–246. <https://doi.org/10.1177/001979391006300203>

- Hair, J. F., Hult, G. T. M., Ringle, C., & Sarstedt, M. (2013). *A primer on partial least squares structural equation modelling (PLS-SEM)*. Sage Publications.
- Hair, J. F., Hult, G. T. M., Ringle, C. M., & Sarstedt, M. (2017). *In: A primer on Partial Least Squares Structural Equation Modeling (PLS-SEM)* (second ed.). Sage Publications.
- Hair, J. F., Risher, J. J., Sarstedt, M., & Ringle, C. M. (2019). When to use and how to report the results of PLS-SEM. *European Business Review*, 31(1), 2–24. <https://doi.org/10.1108/EBR-11-2018-0203>
- Halbesleben, J. R., Harvey, J., & Bolino, M. C. (2009). Too engaged? A conservation of resources view of the relationship between work engagement and work interference with family. *Journal of Applied Psychology*, 94(6), 1452–1465. <https://doi.org/10.1037/a0017595>
- Hancock, J., Allen, D., Bosco, F., McDaniel, K., & Pearce, C. (2013). Meta-analytic review of employee turnover as a predictor of firm performance. *Journal of Management*, 39(3), 573–603. <https://doi.org/10.1177/0149206311424943>
- Henseler, J., Ringle, C. M., & Sarstedt, M. (2015). A new criterion for assessing discriminant validity in variance-based structural equation modeling. *Journal of the Academy of Marketing Science*, 43(1), 115–135. <https://doi.org/10.1007/s11747-014-0403-8>
- Hobfoll, S. E. (Ed.). (1988). *The ecology of stress*. Hemisphere. Hobfoll.
- Hoch, J. E., Bommer, W. H., Dulebohn, J. H., & Wu, D. (2018). Do ethical, authentic, and servant leadership explain variance above and beyond transformational leadership? A meta-analysis. *Journal of Management*, 44(2), 501–529. <https://doi.org/10.1177/0149206316665461>
- Hom, P. W., Mitchell, T. R., Lee, T. W., & Griffeth, R. W. (2012). Reviewing employee turnover: Focusing on proximal withdrawal states and an expanded criterion. *Psychological Bulletin*, 138(5), 831–858. <https://doi.org/10.1037/a0027983>
- Hossain, M. I., Muniaudy, K., Nasiruzzaman, M., & Karim, A. (2018). Factors influencing employee turn over rate at call centres: A case study on AEON credit service Malaysia. *IOSR Journal of Business and Management*, 20(5), 7–15. <https://doi.org/10.9790/487X-2005080715>
- ILO. (2020). World employment and social outlook: Trends 2020. Retrieved September 15, 2022 from https://www.ilo.org/global/research/global-reports/weso/2020/WCMS_734455/lang-en/index.html
- Kang, I. G., Croft, B., & Bichelmeyer, B. A. (2021). Predictors of turnover intention in U.S. federal government workforce: machine learning evidence that perceived Comprehensive HR practices predict turnover intention. *Public Personnel Management*, 50(4), 538–558. <https://doi.org/10.1177/0091026020977562>
- Kelloway, E. K., Gottlieb, B. H., & Barham, L. (1999). The source, nature, and direction of work and family conflict: A longitudinal investigation. *Journal of Occupational Health Psychology*, 4(4), 337–346. <https://doi.org/10.1037/1076-8998.4.4.337>
- Kenri, R. M., Muthuveloo, T. A. P., & Rahman, R. A., (2013). Turnover intention trend among commercial banks in Penang, Malaysia. *Proceedings of the International Conference on Entrepreneurship and Business Management*, November, 21–22, Sanur, Bali(pp. 21–22).
- Khalil, M. I., Haque, R., Senathirajah, A. B. S., Connie, G., & Chowdhury, B. (2022). Entrepreneurial leadership effect on SME's performance in Malaysia. *International Journal of Health Sciences*, 6, 10758–10775. <https://doi.org/10.53730/ijhs.v6n55.10879>
- Kim Siew, L. (2017). Analysis of the relationship between leadership styles and turnover intention within small medium enterprise in Malaysia. *Journal of Arts & Social Sciences*, 1(1), 1–11. <https://ruijass.com/analysis-of-the-relationship-between-leadership-styles-and-turnover-intention-within-small-medium-enterprise-in-malaysia/>
- Kline, R. B. (2011). *Principles and practice of structural equation modeling* (3rd ed.). Guilford Press.
- Kline, R. B. (2015). *Principles and Practice of Structural Equation Modeling* (4th ed.). Guilford Publications, New York.
- Kuenzi, M., Mayer, D. M., & Greenbaum, R. L. (2020). Creating an ethical organizational environment: The relationship between ethical leadership, ethical organizational climate, and unethical behavior. *Personnel Psychology*, 73(1), 43–71. <https://doi.org/10.1111/peps.12356>
- Lee, X., Yang, B., & Li, W. (2017). The influence factors of job satisfaction and its relationship with turnover intention: Taking early-career employees as an example. *Anales de Psicología*, 33(3), 697. <https://doi.org/10.6018/analesps.33.3.238551>
- Leiter, M. P., & Maslach, C. (2009). Nurse turnover: The mediating role of burnout. *Journal of Nursing Management*, 17(3), 331–339. <https://doi.org/10.1111/j.1365-2834.2009.01004.x>
- Leiter, M. P., & Schaufeli, W. B. (1996). Anxiety, stress & coping: An consistency of the burnout construct across occupations consistency of the burnout construct. *Anxiety, Stress & Coping: An International Journal*, 9(3), 229–243. <https://doi.org/10.1080/10615809608249404>
- Loh, M. Y., Idris, M. A., Dormann, C., & Muhamad, H. (2019). Organisational climate and employee health outcomes: A systematic review. *Safety Science*, 118 (October 2017), 442–452. <https://doi.org/10.1016/j.ssci.2019.05.052>
- Martin, K. D., & Cullen, J. B. (2006). Continuities and extensions of ethical climate theory: A meta-analytic review. *Journal of Business Ethics*, 69(2), 175–194. <https://doi.org/10.1007/s10551-006-9084-7>
- Maslach, C., & Leiter, M. P. (2017). New insights into burnout and health care: Strategies for improving civility and alleviating burnout. *Medical Teacher*, 39(2), 160–163. <https://doi.org/10.1080/0142159X.2016.1248918>
- Maslach, C., & Leiter, M. P. (2018). Understanding the burnout experience: Recent research and its implications for psychiatry. *World Psychiatry*, 15(2), 103–111. <https://doi.org/10.1002/wps.20311>
- Maslach, C., Schaufeli, W. B., & Leiter, M. P. (2001). Job burnout. *Annual Review of Psychology*, 52(1), 397–422. <https://doi.org/10.1146/annurev.psych.52.1.397>
- Mehmood, M. S., Jian, Z., Akram, U., & Tariq, A. (2021). Entrepreneurial leadership: The key to develop creativity in organizations. *Leadership & Organization Development Journal*, 42(3), 434–452. <https://doi.org/10.1108/LODJ-01-2020-0008>
- Memon, M. A., Salleh, R., & Baharom, M. N. R. (2016). The link between training satisfaction, work engagement and turnover intention. *European Journal of Training & Development*, 40(6), 407–429. <https://doi.org/10.1108/EJTD-10-2015-0077>
- Musa, H., & Chinniah, M. (2016). Malaysian SMEs development: Future and challenges on going green. *Procedia-Social & Behavioral Sciences*, 224, 254–262. <https://doi.org/10.1016/j.sbspro.2016.05.457>
- Nasharudin, M. N. A., Idris, M. A., Loh, M. Y., & Tuckey, M. (2020). The role of psychological detachment in burnout and depression: A longitudinal study of Malaysian workers. *Scandinavian Journal of Psychology*. <https://doi.org/10.1111/sjop.12622>

- Neubert, M. J., Carlson, D. S., Kacmar, K. M., Roberts, J. A., & Chonko, B. L. (2009). The virtuous influence of ethical leadership behavior: Evidence from the field. *Journal of Business Ethics*, 90(2), 157–170. <https://doi.org/10.1007/s10551-009-0037-9>
- Newman, A., Round, H., Bhattacharya, S., & Roy, A. (2017). Ethical climates in organizations: A review and research agenda. *Business Ethics Quarterly*, 27(4), 475–512. <https://doi.org/10.1017/beq.2017.23>
- Ogunfowora, B., Weinhardt, J. M., & Hwang, C. C. (2021). Abusive supervision differentiation and employee outcomes: The roles of envy, resentment, and insecure group attachment. *Journal of Management*, 47(3), 623–653. <https://doi.org/10.1177/0149206319862024>
- O’Keefe, D. F., Howell, G. T., & Squires, E. C. (2019). Ethical leadership begets ethical leadership: Exploring situational moderators of the trickle-down effect. *Ethics and Behavior*, 1(1), 1–20. <https://doi.org/10.1080/10508422.2019.1649676>
- Okpozo, A. Z., Gong, T., Ennis, M. C., & Adenuga, B. (2017). Investigating the impact of ethical leadership on aspects of burnout. *Leadership and Organization Development Journal*, 38(8), 1128–1143. <https://doi.org/10.1108/LODJ-09-2016-0224>
- Palanski, M., Newman, A., Leroy, H., Moore, C., Hannah, S., & Den Hartog, D. (2021). Quantitative research on leadership and business ethics: Examining the state of the field and an agenda for future research. *Journal of Business Ethics*, 168(1), 109–119. <https://doi.org/10.1007/s10551-019-04267-9>
- Paterson, T. A., & Huang, L. (2018). Am I expected to be ethical? A role-definition perspective of ethical leadership and unethical behavior. *Journal of Management*, XX(X), 014920631877116. <https://doi.org/10.1177/0149206318771166>
- Pinkovetskaia, I. S., Lyubovtseva, E. G., Arbeláez-Campillo, D. F., Rojas-Bahamón, M. J., & Veas Iniesta, D. S. (2020). Small and medium enterprises in Russia and other countries. *Amazonia Investiga*, 9(28), 6–13. <https://doi.org/10.34069/AI/2020.28.04.1>
- Plantiveau, C., Dounavi, K., & Virués-Ortega, J. (2018). High levels of burnout among early-career board-certified behavior analysts with low collegial support in the work environment. *European Journal of Behavior Analysis*, 19(2), 195–207. <https://doi.org/10.1080/15021149.2018.1438339>
- Podsakoff, P. M., MacKenzie, S. B., & Podsakoff, N. P. (2012). Sources of method bias in social science research and recommendations on how to control it. *Annual Review of Psychology*, 63(1), 539–569. <https://doi.org/10.1146/annurev-psych-120710-100452>
- Ponomarev, B., Boardman, P., & Boysen, R. (2020). When management matters more than leadership. *International Journal of Public Administration*, 00(0), 1–13. <https://doi.org/10.1080/01900692.2020.1721531>
- Pooja, A. A., De Clercq, D., & Belausteguigoitia, I. (2016). Job stressors and organizational citizenship behavior: The roles of organizational commitment and social interaction. *Human Resource Development Quarterly*, 27(3), 373–405. <https://doi.org/10.1002/hrdq.21258>
- Preacher, K. J., & Hayes, A. F. (2008). Asymptotic and resampling strategies for assessing and comparing indirect effects in multiple mediator models. *Behavioral Research Methods*, 40(3), 879–891. <https://doi.org/10.3758/BRM.40.3.879>
- Pucic, J. (2015). Do as i say (and Do): Ethical leadership through the eyes of lower ranks. *Journal of Business Ethics*, 129(3), 655–671. <https://doi.org/10.1007/s10551-014-2190-z>
- Purvanova, R. K., & Muros, J. P. (2010). Gender differences in burnout: A meta-analysis. *Journal of Vocational Behavior*, 77(2), 168–185. <https://doi.org/10.1016/j.jvb.2010.04.006>
- Queiri, A., Wan Yusoff, W. F., & Dwaikat, N. (2015). Explaining generation-Y employees’ turnover in Malaysian context. *Asian Social Science*, 11(10), 126–138. <https://doi.org/10.5539/ass.v11n10p126>
- Rabl, T. (2011). The impact of situational influences on corruption in organizations. *Journal of Business Ethics*, 100(1), 85–101. <https://doi.org/10.1007/s10551-011-0768-2>
- Reb, J., Narayanan, J., Chaturvedi, S., & Ekkirala, S. (2017). The mediating role of emotional exhaustion in the relationship of mindfulness with turnover intentions and job performance. *Mindfulness*, 8(3), 707–716. <https://doi.org/10.1007/s12671-016-0648-z>
- Reina, C. S., Kristie, M. R., Suzanne, J. P., Kris, B., & Peter, W. H. (2018). Quitting the boss? The role of manager influence tactics and employee emotional engagement in voluntary turnover. *Journal of Leadership & Organizational Studies*, 25(1), 5–18. <https://doi.org/10.1177/1548051817709007>
- Riisla, K., Wendt, H., Babalola, M. T., & Euwema, M. (2021). Building cohesive teams—the role of leaders’ bottom-line mentality and behavior. *Sustainability*, 13(14), 1–19. <https://doi.org/10.3390/su13148047>
- Rondeau, K. V., & Wagar, T. H. (2016). Human resource management practices and nursing turnover. *Journal of Nursing Education and Practice*, 6(10). <https://doi.org/10.5430/jnep.v6n10p101>
- Rönkkö, M., & Cho, E. (2022). An updated guideline for assessing discriminant validity. *Organizational Research Methods*, 25(1), 6–14. <https://doi.org/10.1177/1094428120968614>
- Saleh, T. A., Mehmood, W., Khan, J., & Jan, F. U. (2022). The impact of ethical leadership on employees turnover intention: An empirical study of the banking sector in Malaysia. *The Journal of Asian Finance, Economics and Business*, 9(2), 261–272. <https://doi.org/10.13106/jafeb.2022.vol9.no2.0261>
- Saleh, T. A., Sarwar, A., Islam, A., Mohiuddin, M., & Su, Z. (2022). Effects of leader conscientiousness and ethical leadership on employee turnover intention: The mediating role of individual ethical climate and emotional exhaustion. *International Journal of Environmental Research and Public Health*, 19(15), 8959. <https://doi.org/10.3390/ijerph19158959>
- Sarstedt, M., Ringle, C. M., & Hair, J. F. (2020). Partial Least Squares Structural Equation Modeling. In Christian, H., Martin, K., & Arnd, V. (Eds.), *Handbook of Market Research* (1st ed.) (pp. 587–632). Springer Cham. <https://doi.org/10.1007/978-3-319-05542-8>
- Sausa-Poza, A., & Sousa-Poza, A. A. (2007). The effect of Job satisfaction on labour turnover by gender: An analysis for Switzerland. *The Journal of Socio-Economics*, 36(6), 895–913. <https://doi.org/10.1016/j.socec.2007.01.022>
- Siew, J. F., Wong, S. C., & Lim, C. S. (2023). Should I go or should i stay: Job hopping in Malaysia small medium enterprise (SME) service sectors. *European Journal of Training & Development*, 47(1/2), 105–122. <https://doi.org/10.1108/EJTD-05-2021-0054>
- Sija, A. (2021). The influence of job satisfaction and its effect on employee turnover intention in financial service industry of Malaysia. *European Journal of Economic and Financial Research*, 5(1). <https://doi.org/10.46827/ejefr.v5i1.1066>
- Skelton, A. R., Nattress, D., & Dwyer, R. J. (2019). Predicting manufacturing employee turnover intentions. *Journal of Economics, Finance and Administrative Science*, 25(49), 101–117. <https://doi.org/10.1108/JEFAS-07-2018-0069>

- SME Corp Malaysia. (2019). Entrepreneurship driving SMEs. SME Annual Report 2018/2019. http://smecorp.gov.my/images/SMEAR/SMEAR2018_2019/final/english/SMEAR-English-AllChapterFinal24Jan2020.pdf
- Suifan, T. S., Diab, H., Alhyari, S., & Sweis, R. J. (2020). Does ethical leadership reduce turnover intention? The mediating effects of psychological empowerment and organizational identification. *Journal of Human Behavior in the Social Environment*, 1(1), 1–19. <https://doi.org/10.1080/10911359.2019.1690611>
- Svensson, G., Ferro, C., Høgevoid, N., Padin, C., Carlos Sosa Varela, J., & Sarstedt, M. (2018). Framing the triple bottom line approach: Direct and mediation effects between economic, social and environmental elements. *Journal of Cleaner Production*, 197, 972–991. <https://doi.org/10.1016/j.jclepro.2018.06.226>
- Tarallo, M. (2018). Society of human resource management how to reduce employee turnover through robust retention strategies. <https://www.shrm.org/resourcesandtools/hr-topics/talent-acquisition/pages/how-to-reduce-employee-turnover-throughrobust-retention-strategies.aspx>
- Tehseen, S., Ramayah, T., & Sajilan, S. (2017). Testing and controlling for common method variance: A review of available methods. *Journal of Management Sciences*, 4(2), 142–168. <https://doi.org/10.20547/jms.2014.1704202>
- Teresi, M., Pietroni, D. D., Barattucci, M., Giannella, V. A., & Pagliaro, S. (2019). Ethical climate(s), organizational identification, and employees' behavior. *Frontiers in Psychology*, 10(June). <https://doi.org/10.3389/fpsyg.2019.01356>
- Tett, R. P., & Meyer, J. P. (1993). Job satisfaction, organizational commitment, turnover intention, and turnover: Path analyses based on meta-analytic findings. *Personnel Psychology*, 46(2), 259–293. <https://doi.org/10.1111/j.1744-6570.1993.tb00874.x>
- Tourangeau, R., Rips, L. J., & Rasinski, K. (2000). *The psychology of survey response*. Cambridge University Press.
- Ullah, Z., Otero, S. Á., Sulaiman, M. A., Sial, M. S., Ahmad, N., Scholz, M., & Omhand, K. (2021). Achieving organizational social sustainability through electronic performance appraisal systems: The moderating Influence of transformational leadership. *Sustainability*, 13(10), 1–14. <https://doi.org/10.3390/su13105611>
- Upadyaya, K., & Salmela-Aro, K. (2020). Social demands and resources predict job burnout and engagement profiles among Finnish employees. *Anxiety, Stress and Coping*, 33(4), 403–415. <https://doi.org/10.1080/10615806.2020.1746285>
- Victor, B., & Cullen, J. B. (1988). The organizational bases of ethical work climates. *Administrative Science Quarterly*, 33(1), 101. <https://doi.org/10.2307/2392857>
- Wen, B., Zhou, X., Hu, Y., & Zhang, X. (2020). Role stress and turnover intention of front-line hotel employees: The roles of burnout and service climate. *Frontiers in Psychology*, 11(1), 1–13. <https://doi.org/10.3389/fpsyg.2020.00036>
- The World Bank. (2020). Small and medium enterprises (SMEs) finance. <https://www.worldbank.org/en/topic/sme/finance>
- Xu, S., Martinez, L. R., Van Hoof, H., Estrella Duran, M., Maldonado Perez, G., & Gavilanes, J. (2018). Emotional exhaustion among hotel employees: The interactive effects of affective dispositions and positive work reflection. *Cornell Hospitality Quarterly*, 59(3), 285–295. <https://doi.org/10.1177/1938965517748774>
- Yukl, G., Mahsud, R., Prussia, G., & Hassan, S. (2019). Effectiveness of broad and specific leadership behaviors. *Personnel Review*, 48(3), 774–783. <https://doi.org/10.1108/PR-03-2018-0100>
- Zaharee, M., Lipkie, T., Mehlman, S. K., & Neylon, S. K. (2018). Recruitment and retention of early-career technical talent: What young employees want from employers. *Research Technology Management*, 61(5), 51–61. <https://doi.org/10.1080/08956308.2018.1495966>
- Zhang, C., Mayer, D. M., & Hwang, E. (2017). More is less: Learning but not relaxing buffers deviance under job stressors. *Journal of Applied Psychology*, 103(2), 123–136. <https://doi.org/10.1037/apl0000264>